

## TANK:

300 Gallons Water.  
15 Gallons Foam - Optional  
High-strength polypropylene  
integrated to the body.

## CHASSIS:

**FORD 450 XL / Option 550 XL**  
Crew Cab, 4x4. 179.8" WB, 60.0"  
CA.

Engine: 6.7 Power Stroke V8  
Turbo Diesel.

Transmission: 10-speed  
TorqShift automatic  
transmission.

## PUMP:

Engine Pump HALE HPX75-B18

## FOAM PROPORTIONING SYSTEM:

Trident FOAMATE.  
Around-The-Pump system.  
Class A.

## BODY AND COMPARTMENTS:

Lightweight integrated  
construction.  
High-strength polypropylene  
1 compartment per side.  
Aluminum roll-up doors.

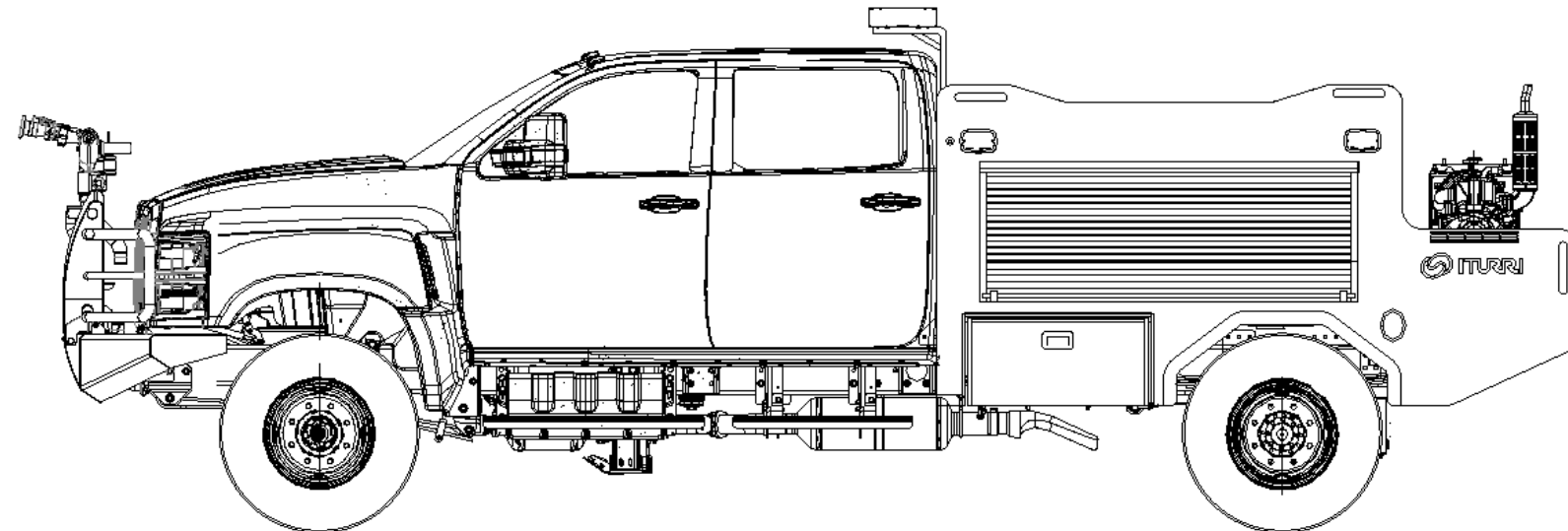

NWCG Compliant Apparatus

## INTAKES / DISCHARGES:

High flow TIG welded stainless  
steel discharge and suction  
manifolds.

Rear Discharges:

- 2 x 1 ½"\*
- 1 x 1"\*
- 1 x 1" - Hose Reel

Front Discharges:

- 1 x 2" - Monitor
- 1x 1 ½"\*

Suction: 2.1/2"

Tank Fill: 1x 1 1/2"\*

Valves options: Akron, Elkhart  
Brass, Trident.

## HOSE REEL:

Hannay Reel INC.  
100ft 1" booster hose  
Located in rear compartment

## MONITOR OPTIONS:

Elkhart Brass 8495  
Akron Forestry 3462  
Cab controlled.  
Located in front bumper.

## LIGHTING:

Emergency and priority lighting  
package.  
Transit lighting according to law.



EcoPolyFire® is a building technology using high-strength polypropylene with integrated tanks and body in a monoblock structure. More advanced, heavy-duty and lighter bodies, maximizing the tanks and lockers capacities.



## 25 YEARS WARRANTY



**Flexibility:** EPF® can absorb the energy and dissipate it in the surface, avoiding the tension concentrations which produce failures



**Maintenance:** EcoPolyFire does not need any preventive maintenance during its complete lifecycle



**Density:** Significantly lighter than conventional body systems allowing to increase the payload and therefore the tank capacity



**Compartments:** High flexibility in interior design Maximizes cargo capacity



**Monoblock Concept Design:** It allows the use of 100% bodywork volume



**Recycling:** All components built in EcoPolyFire are 100% recyclable



**High Thermal Resistance**



**Potability:** Tanks made of EcoPolyFire are compatible with the use of drinkable water



**100% Corrosion-free:** The material is fully resistant against corrosion





## OPTIONS

- HEAVY DUTY FRONT BUMPER
- AKRON FORESTRY 3462 MONITOR
- ELKHART BRASS BRUSHHAWK 8495 MONITOR
- AUXILIARY ENGINE PUMP CHANGE: FROM HALE HPX75-B18 (GAS) TO DARLEY 1-1/2 AGE 10YDW - DIESEL (\*)
- OFF ROAD DUAL TIRE 255/70R22.5
- SUPER SINGLE REAR WHEELS - 335/80R20
- FRONT WINCH WARN 16T- 12V ELECTRIC
- GROUND SWEEPS.
- HOIST FOR SPARE WHEEL.
- LIGHTING PROTECTION GUARD KIT
- AUXILIARY GAS TANK - 25GAL ADD
- CORK COATING ON BODYWORK - ITURRI COVER MATERIAL.
- ONLY FOR WILDLAND 6 - CHANGE OF CHASSIS TO FORD 550
- ONLY FOR WILDLAND 6 - CHANGE OF CHASSIS TO INTL CV515
- FRONT BUMPER ENCLOSED TRAY FOR 30 FEET 1,5 HOSE - NOT COMPATIBLE WITH FRONT WINCH. ONLY W/OPTION HEAVY DUTY BUMPER POPT1.
- FRONT BUMPER SMALL TRAY FOR 15 FEET 1,5 HOSE - COMPATIBLE WITH FRONT WINCH AND MONITOR. ONLY W/OPTION HEAVY DUTY BUMPER POPT1.
- OPTICOM - OPTICOM® INFRARED SYSTEM
- COLD WEATHER KIT - OPERATIONS USE: ENGINE BLOCK HEATER + HALE HEAT EXCHANGER
- FRONT BUMPER SKID PROTECTION PANEL
- REAR STEP #2