

- FEATURES:**
- INTERNATIONAL CV515 4X4 CHASSIS
  - HALE CBP 250gpm / DARLEY HM250 / 350
  - AUXILIARY ENGINE PUMP (GAS OR DIESEL)- OPTIONAL
  - TANK CAPACITY: 600gal WATER+ 15gal FOAM
  - HANNAY HOSE REEL - 1" X 100ft
  - FULLY CUSTOMIZABLE STORAGE COMPARTMENTS
  - 2 - 1 1/2" DISCHARGE
  - 1 - 1" DISCHARGE
  - 1 - 1 1/2" FRONT DISCHARGE
  - 1 - 2 1/2" SUCTION INTAKE
  - 1 - 2 1/2" TANK FILL
  - 1 - 2" FRONT MONITOR - OPTIONAL
  - DUAL AND SINGLE TIRE SIZE OPTIONS

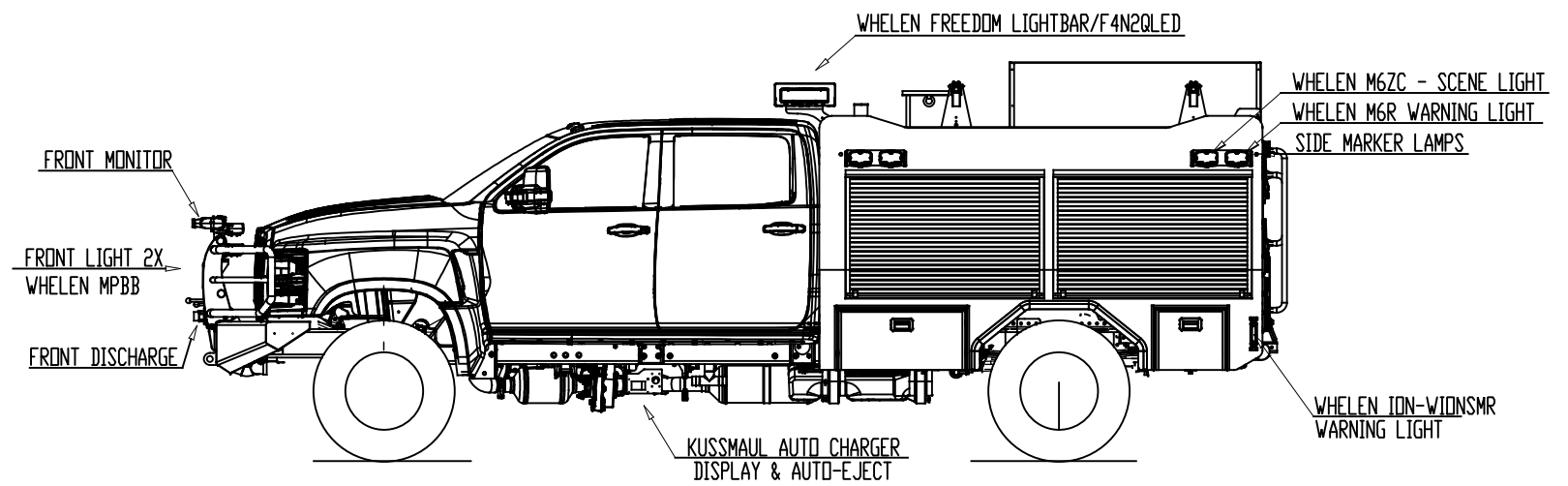
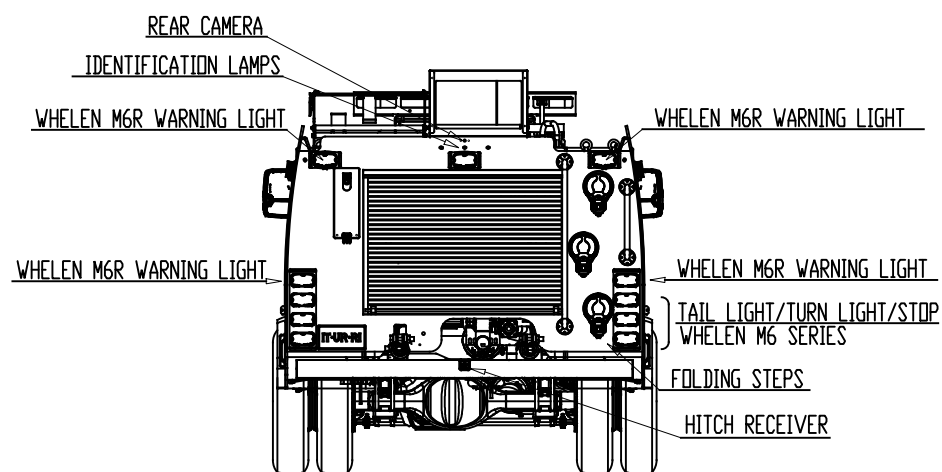
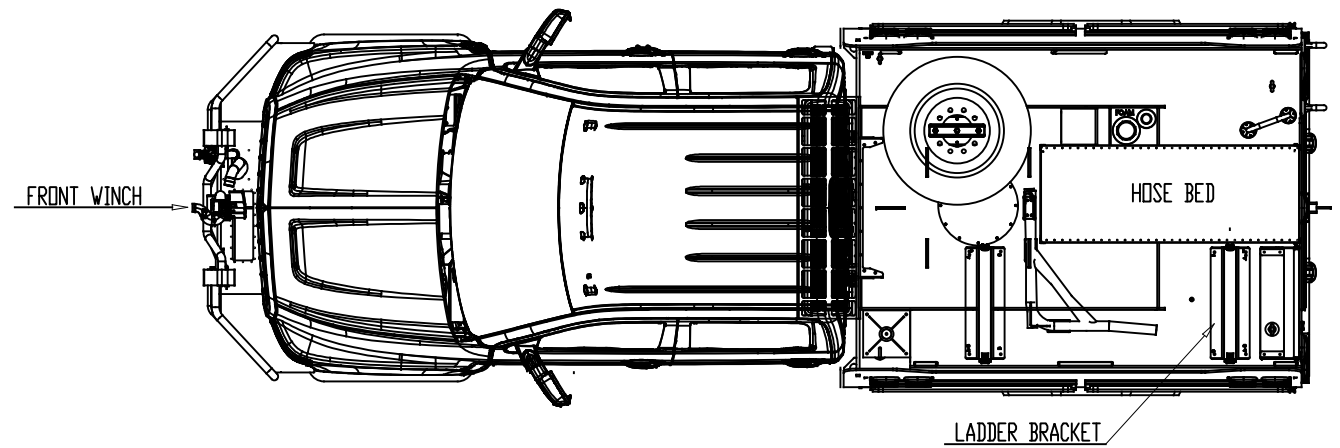

The information contained in this document is property of ITURRI, S.A. Unauthorized total or partial copy to third parties is strictly prohibited.

**NOTE:**  
ALL MEASUREMENTS AND PERFORMANCES ARE CALCULATED ACCORDING TO INFORMATION SUPPLIED BY THE VEHICLE'S MANUFACTURER. ITURRI RESERVES THE RIGHT TO MAKE DESIGN MODIFICATIONS WITHOUT PRIOR NOTICE

Unit: in

	NAME	DATE	PRODUCT NAME:	CODE:
	DESIGNED	MJP	3/29/2024	ITURRI WILDLAND 3 INITIAL ATTACK
	APPROVED	EDL	3/29/2024	DRAWING: G2862 00 000 00
				SHEET: 1 OF 1